



native|art

Modular 3D Porcelain and Ceramic Tiles

Inspired by the earth diversity and colours





Modular 3D Porcelain and Ceramic Tiles



ABOUT US

Native Art is a registered trademark of İlksem Mühendislik Ar-Ge Seramik San. Tic. Ltd. Şti., which was founded in 2013 as a technopark company to carry out R&D activities related to ceramic products. Our brand; it has borned as a result of R&D and design studies to contribute to sustainable production by reducing the use of natural resources. In our products, secondary and recycling raw materials are used at varying rates. Native Art has offer wide colour range and design possibility with production capacity of ceramic, porcelain and terracotta to its customers.

Our company; since 2016, it has been producing Native Art products developed as a result of R&D activities. In a short time, it has reached a capacity that can produce modular and handmade, three-dimensional porcelain, ceramic and terracotta coating materials for special architectural projects by developing its product range, model, colour and glaze diversity. It has a production capacity of 72.000 m² per year with its factory of 2500 m² in total, 1000 m² of which is closed and 1500 m² of open area.

Native Art ceramic and porcelain product series suitable for wet spaces are completely handmade and add aesthetics to your living spaces with their easy-to-clean glossy glazed surface and custom hand decoration.

Clay-based terracotta series is suitable for interior and exterior decorative areas. Its designs are modern and culturally inspired. Native Art terracotta offers special designs for architectural projects by combining the texture of the soil and the colors of nature with art.

The restoration works have realized with the "Native Art Cultural Heritage Series" carry the traces of the past to the present. The tiles and ceramics of the period, which were developed in accordance with the original with R&D studies, maintain the magnificence of history.

Our vision is to be a leading and reliable company in the sector, which makes scientific knowledge usable in the industry with the innovative and academic perspective of our expert staff, produces environmentalist, innovative, awareness-raising projects and products in its field.

Our mission is to produce porcelain and ceramic coating materials and projects with environmentalist, aesthetic and technical features according to architectural projects.

Our Values

- * Reliability
- * Originality
- * High quality and efficiency
- * Usefulness
- * Environmental awareness
- * To be a problem solver and to cooperate for the solution



WHAT IS INDUSTRIAL SYMBIOSIS?

Industrial symbiosis is the process by which the waste or by-products of one industry or industrial process become the raw material of another industry. The application of this concept enables a more sustainable use of materials and contributes to the creation of a circular economy.

The transition to such an economy is necessary for our world where resources are increasingly depleted as it will result in increased economic competitiveness, sustainability, resource efficiency and resource security.

Industrial symbiosis creates an interconnected network that tries to mimic the functioning of ecological systems in which energy and materials are constantly converted without any waste products being produced. It aims to reduce the use of primary raw materials and increase the use of secondary raw materials.

Thus industrial symbiosis,

- * Contributes to zero waste generation.
- * It reduces the use of natural resources.
- * Provides efficient use of natural resources.
- * Reduces the needs such as landfill and disposal of wastes for wastes.
- * Allows value to be created from disposable materials, so the materials remain economically valuable for longer than traditional industrial systems.
- * Contributes to the reduction of greenhouse gas emissions.
- * Serves to reduce the environmental footprint of related industries.

Examples of industrial symbiosis are extensive. Examples of industrial symbiosis include the use of waste heat from an industry to hot greenhouses for food production, the recovery of car tire chips for use in construction materials, and the use of sludge from fish farms as agricultural fertilizers.

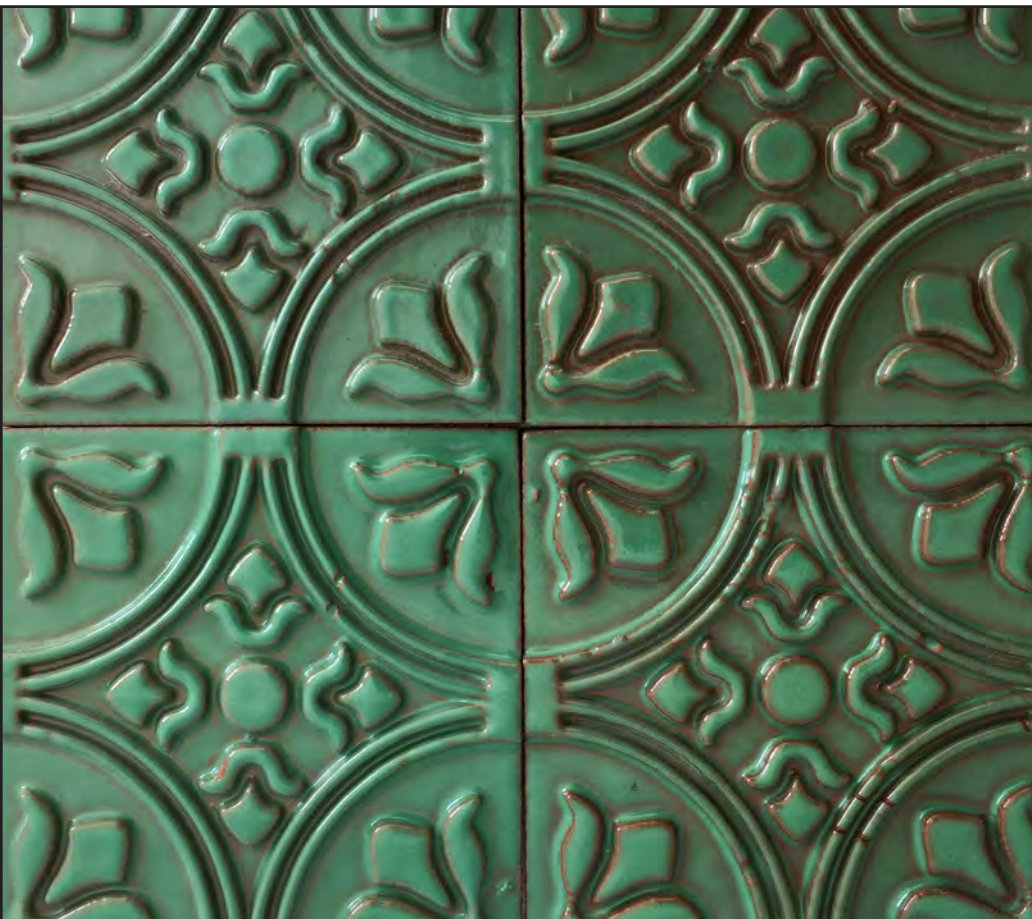
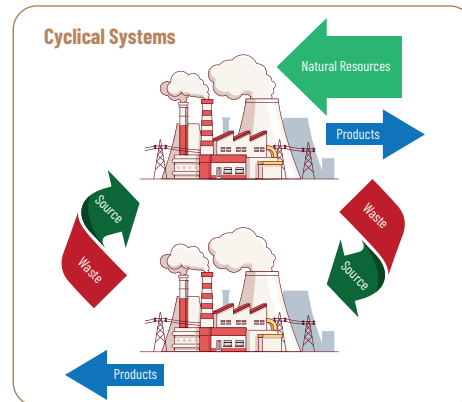
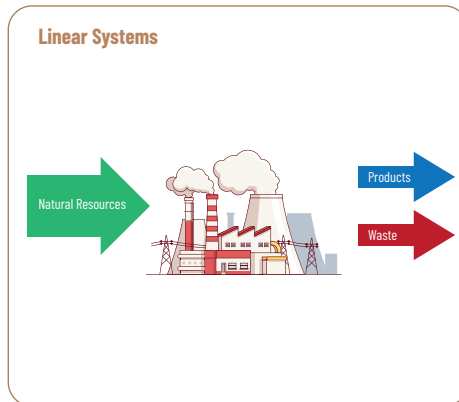



Crosswicker

Product Code: CRW
Sheet Sizes: 340x315 mm
Piece/m² : 12 pcs
Sheet Weight: 1266 g



PORCELAIN MOSAIC TILES

The power of porcelain met mosaic...

We produce water-resistant porcelain mosaic tiles that are suitable for indoor and outdoor use and add high aesthetic value to the spaces.

With our porcelain mosaic tiles that have special clay and glaze features, we have developed with our expert R&D team, we are happy to bring the textures in our cultural history to the present and contribute to the aesthetics of modern times.

Plainwaven

Product Code: PLW
Sheet Sizes: 375x306 mm
Piece/m² : 11 pcs
Sheet Weight: 1390 g

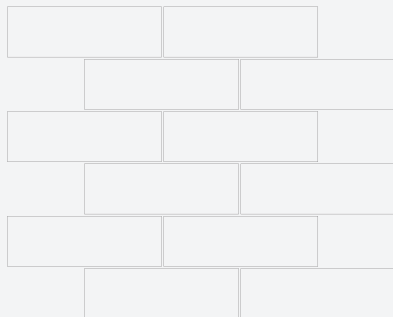
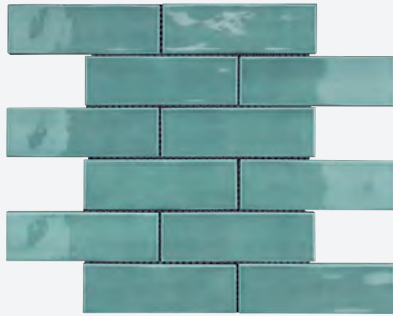

Plainramen

Product Code: PLF
Sheet Sizes: 373x304 mm
Piece/m² : 11 pcs
Sheet Weight: 1397 g

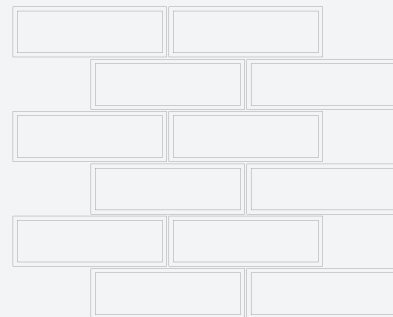



Fencingbold

Product Code: FCB
Sheet Sizes: 308x304 mm
Piece/m² : 12 pcs
Sheet Weight: 1354 g

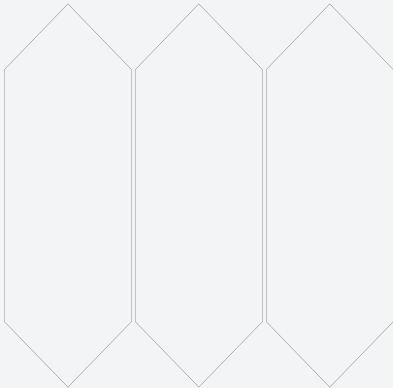
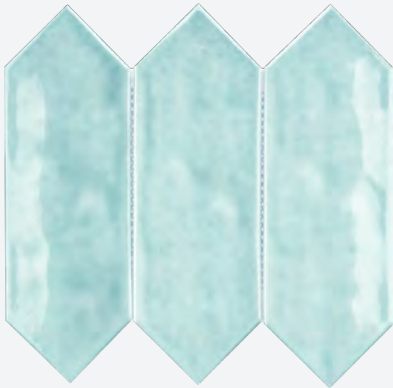

Fencingtall

Product Code: FCT
Sheet Sizes: 324x298 mm
Piece/m² : 12 pcs
Sheet Weight: 1176 g

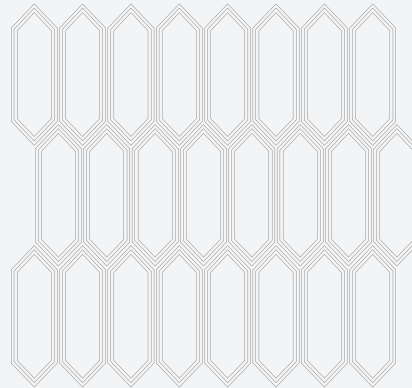
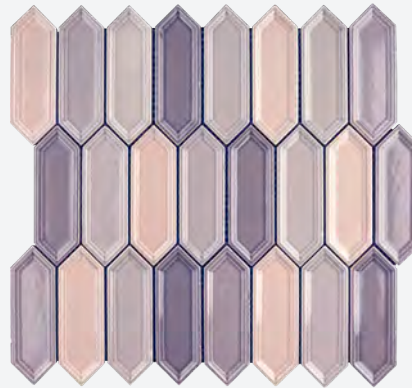



Sparkle

Product Code: SPK
Sheet Sizes: 307x323 mm
Piece/m² : 12 pcs
Sheet Weight: 1246 g

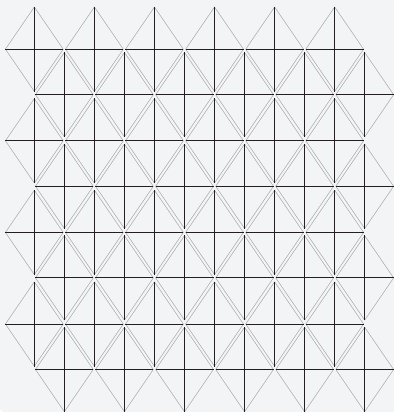
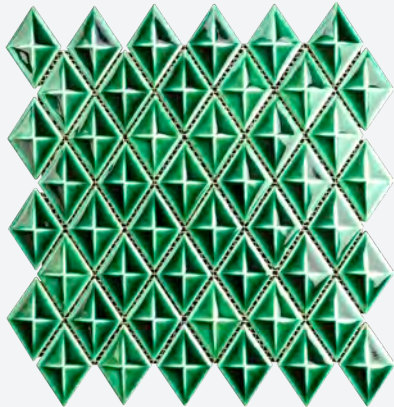
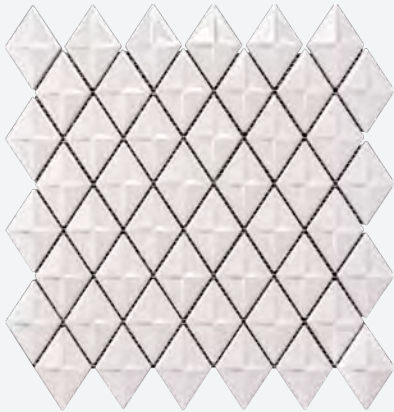

Raindrop

Product Code: RDR
Sheet Sizes: 343x345 mm
Piece/m² : 10 pcs
Sheet Weight: 1233 g

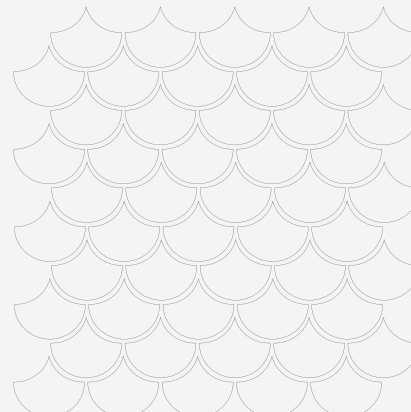
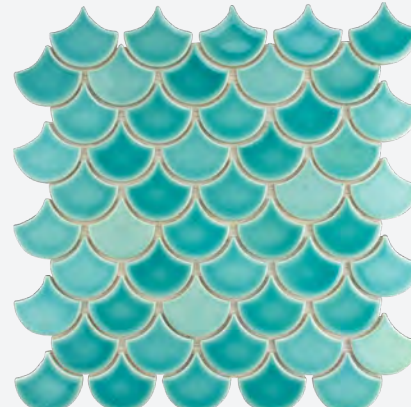
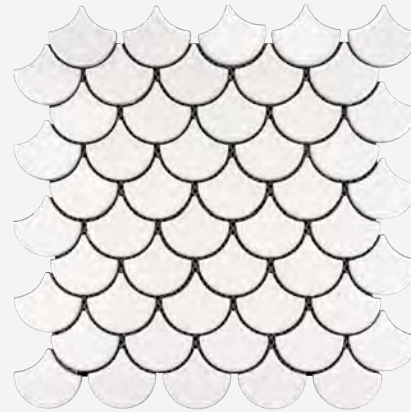



Spadesque Frame

Product Code: SPF
Sheet Sizes: 350x365 mm
Piece/m² : 10 pcs
Sheet Weight: 1359 g

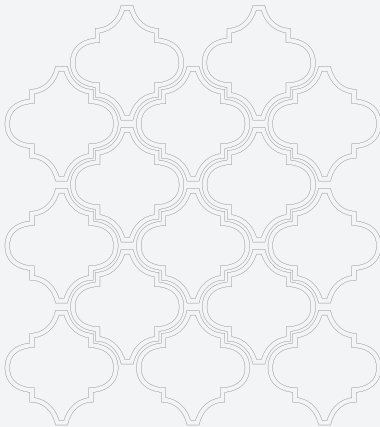
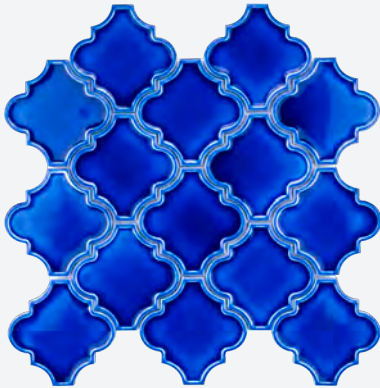
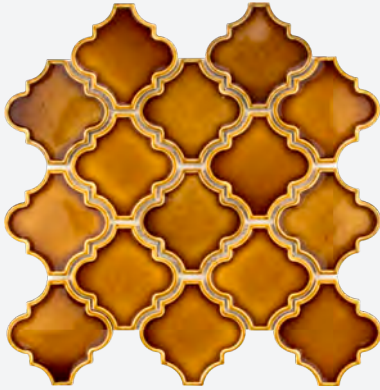

Spadesque

Product Code: SPQ
Sheet Sizes: 347x355 mm
Piece/m² : 11 pcs
Sheet Weight: 1428 g

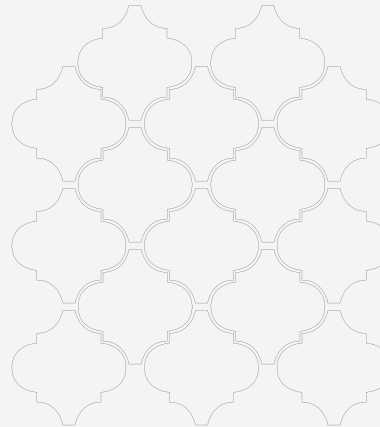
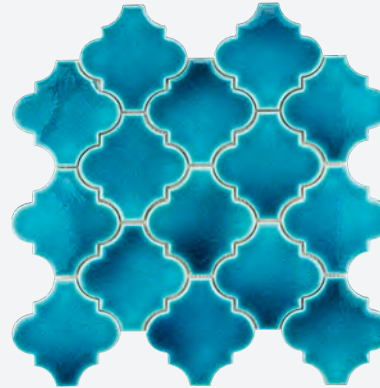
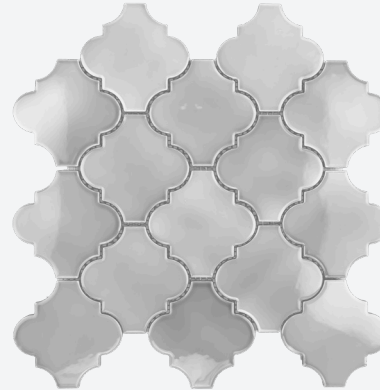



Spadesdrop

Product Code: SPD
Sheet Sizes: 333x336 mm
Piece/m² : 10 pcs
Sheet Weight: 1252 g

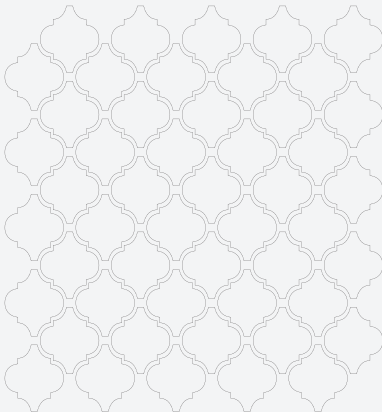
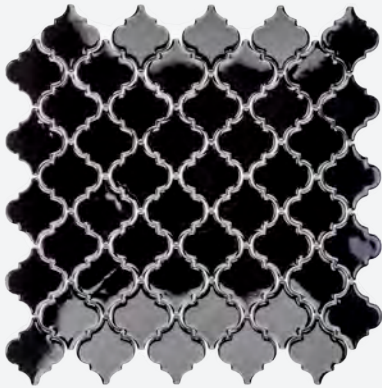
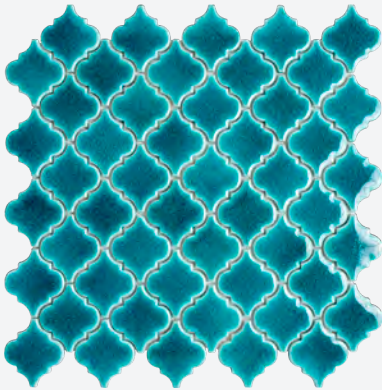

Griddlen

Product Code: GRD
Sheet Sizes: 301x301 mm
Piece/m² : 11 pcs
Sheet Weight: 1144 g

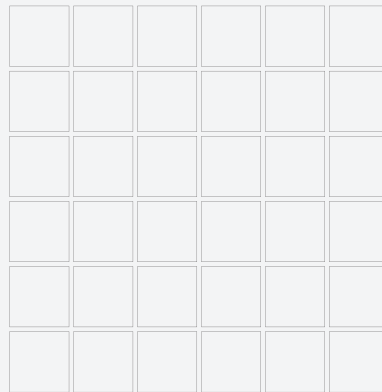
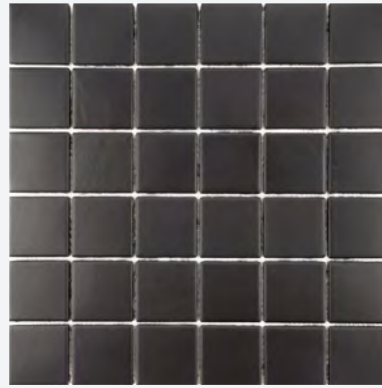



Brickell

Product Code: BRC
Sheet Sizes: 303x260 mm
Piece/m² : 14 pcs
Sheet Weight: 985 g

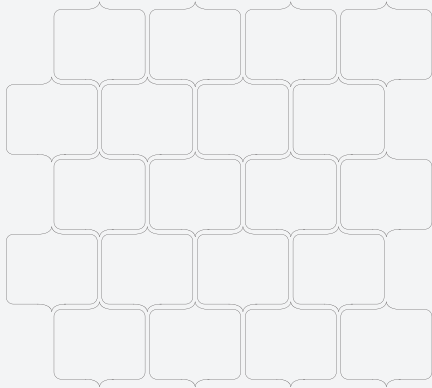
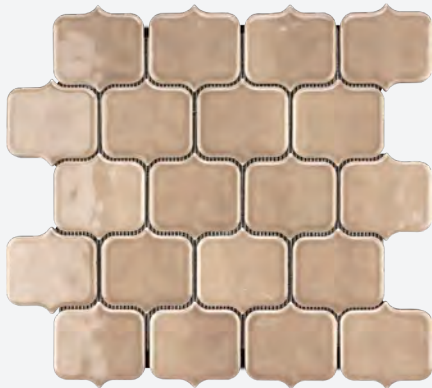
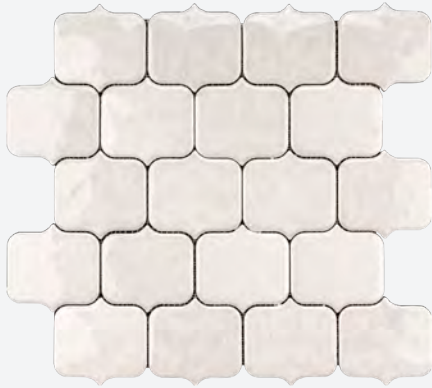

Drop

Product Code: DR0
Sheet Sizes: 450x379 mm
Piece/m² : 13 pcs
Sheet Weight: 1275 g

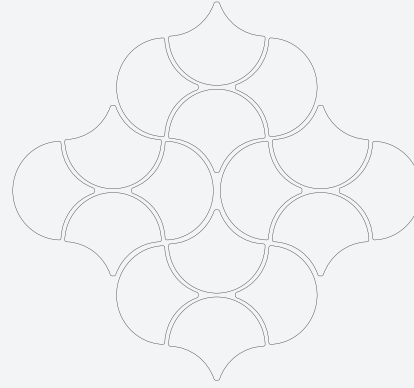



Starmond

Product Code: SRM
Sheet Sizes: 358x296 mm
Piece/m² : 14 pcs
Sheet Weight: 915 g

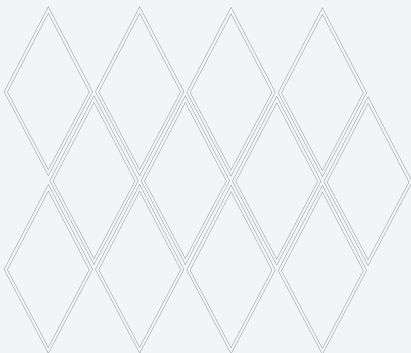
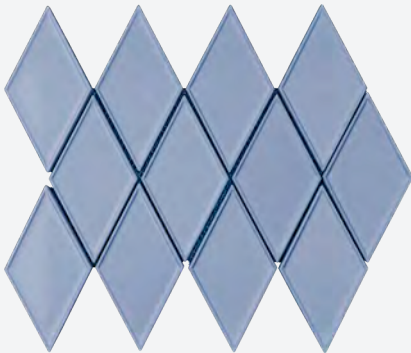

Starmond Edge

Product Code: SRE
Sheet Sizes: 348x325 mm
Piece/m² : 10 pcs
Sheet Weight: 1121 g

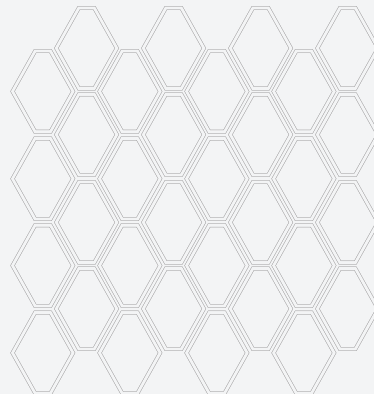
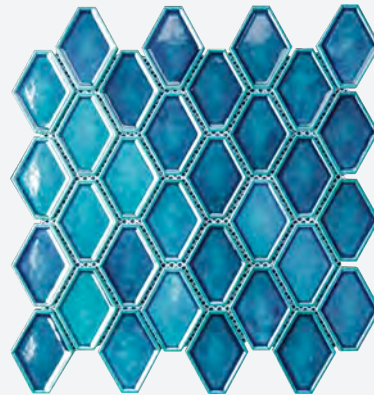
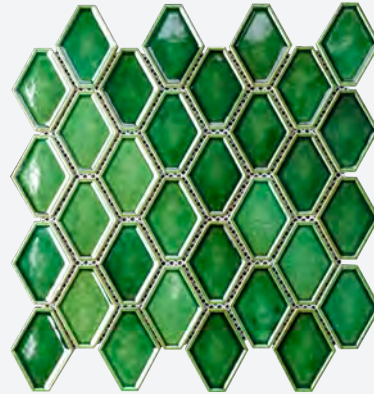



Squaremos

Product Code: SQM
Module Sizes: 250x250 mm
Piece/m² : 16 pcs
Module Weight: 1148 g

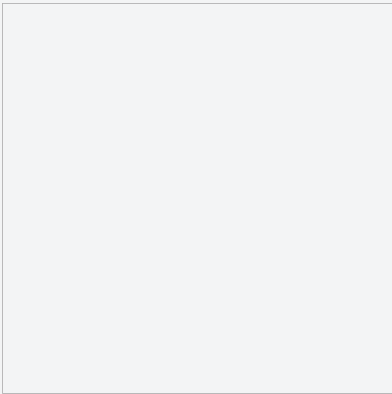

Tefukrelief

Product Code: SJR
Module Sizes: 348x325 mm
Piece/m² : 16 pcs
Module Weight: 1182 g

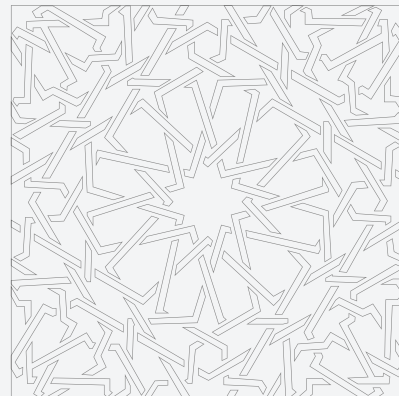
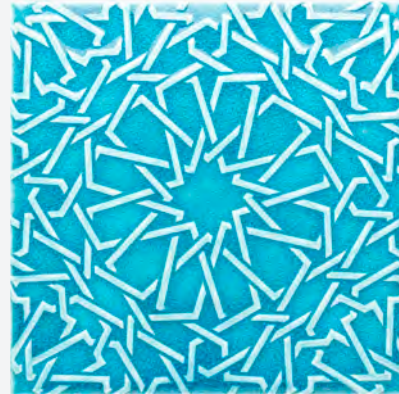
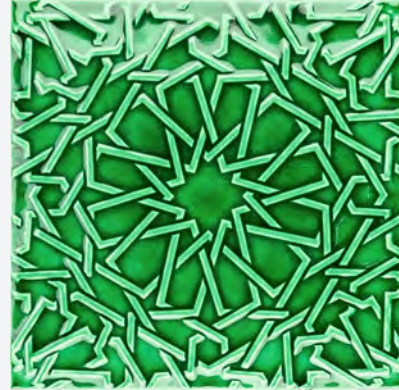



Evensech

Product Code: EVS
Module Sizes: 173x200 mm
Piece/m² : 39 pcs
Module Weight: 500 g

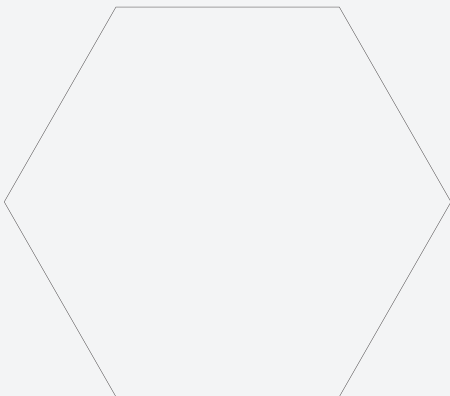
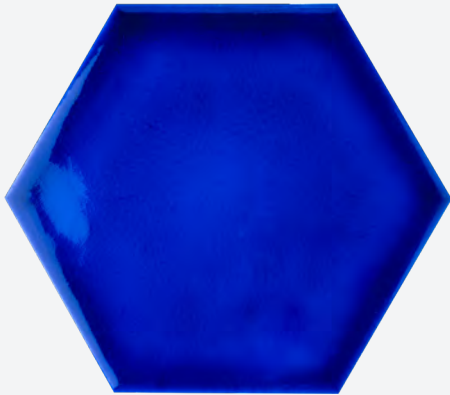
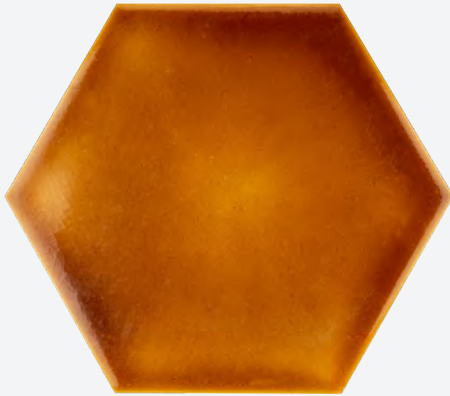

Evensech Relief

Product Code: EVR
Module Sizes: 173x200 mm
Piece/m² : 39 pcs
Module Weight: 500 g

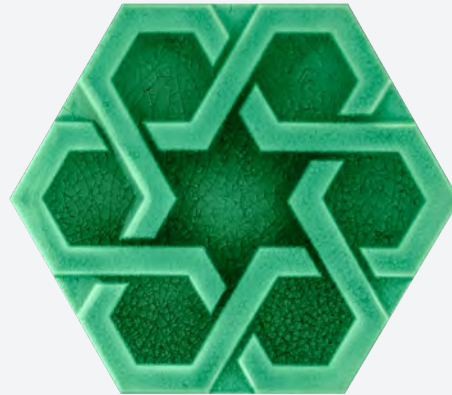



Squarex

Product Code: SQX
Module Sizes: 100x100 mm
Piece/m² : 100 pcs
Module Weight: 139 g

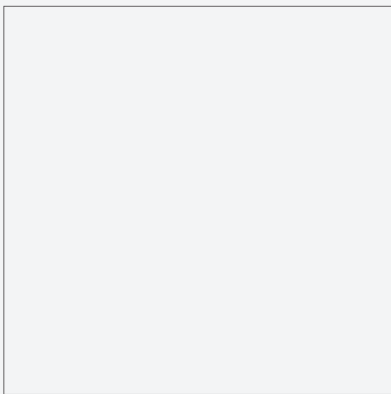
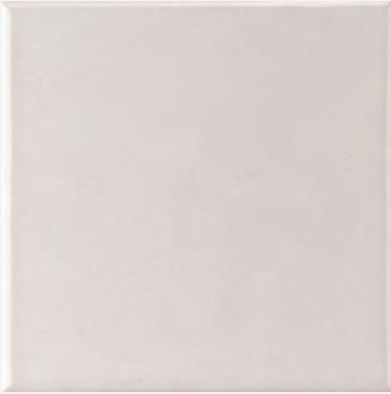

Rosetta

Product Code: RST
Module Sizes: 128x128 mm
Piece/m² : 61 pcs
Module Weight: 272 g

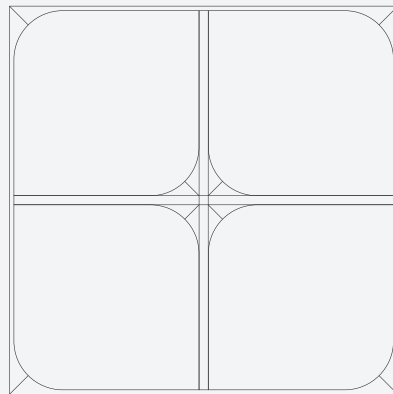
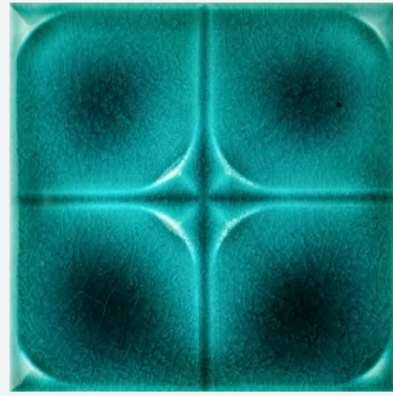
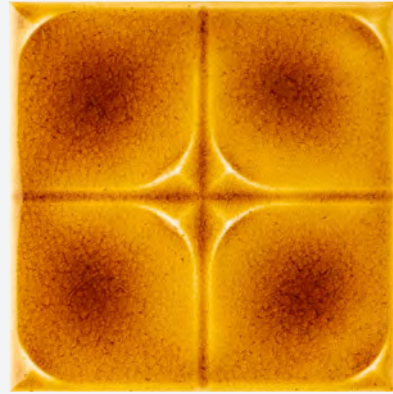



Metro

Product Code: MTR
Module Sizes: 150x75 mm
Piece/m² : 88 pcs
Module Weight: 278 g

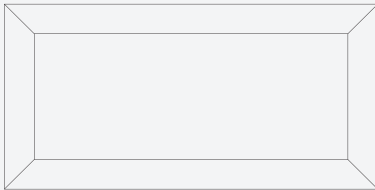

Lane

Product Code: LAN
Module Sizes: 250x50 mm
Piece/m² : 80 pcs
Module Weight: 211 g

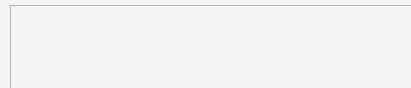



 native art



CERAMIC TILES

An artistic touch to your living spaces...

Our clay-based Terracotta and ceramic Stoneware product group is suitable for interior and exterior use. It is completely handmade and its designs bear modern and cultural influences.

We offer special designs for your projects by combining the texture of the soil and the colors of nature with art.



We carry **THE TRACES of** *OLD TIMES to the* **FUTURE**

Native Art manufactures period tile-brick mixed tile mosaics, Iznik tiles in accordance with their originals, in restoration works carried out to protect our cultural heritage.

For this purpose, intensive R&D studies are carried out with a team of experts with many studies, technical and academic knowledge about period tiles.

Handmade tiles produced with intensive effort ensure that our cultural heritage is transferred to the next generations with the same majesty.

Iznik Tile Series

Tile art was founded in the 14th century and, in the 15th century he lived in the golden period by finding life in the master hands in Iznik. Tile art is not only technically and aesthetically perfect, but also unique in its deep meanings. The roses and gorges in the patterns symbolize the smell of the Prophet's skin, love and beauty. The fact that the word tulip contains the same letters as the word Allah in Ottoman indicates the unity of Allah.

In Native Art, the original Iznik tiles are produced in accordance with the structure of technical structure and aesthetic pattern studies are carried out inspired by our culture.



Iznik Stone Tile
(Elif - Turquoise)



Iznik Stone Tile
(Elif - Blue-White Decor)

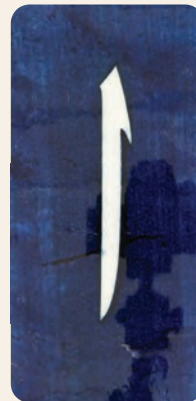

Iznik Stone Tile
(Elif - Cobalt)



THE TIMELESS HERITAGE
of modern times...

Cultural Heritage Series

Cultural heritage, belonging to a community, are long-term shares in that society. It represents our history, our identity, our connection to the past, to the present and to the future. The Anatolian geography on which we live is very rich in terms of cultural heritage as it is one of the rare areas where humanity first appeared, the first civilizations began, science and cultures developed.

There are many works adorned with tiles and ceramics in this heritage. Starting from relatively recent history, these works are referred to as Ottoman – iznik period with technically and aesthetically perfect white tiles and unique decorations made with tiles and bricks in a great architecture of the Seljuk period. Native Art products are both inspired by this unique cultural heritage and contribute to this cultural heritage.

**Colour and decor works can be carried out in accordance with customer request. Since our products are handmade and boutique-style manufacturing, there may be colour tone differences within and between product batches.*

Seljuk Mosaic

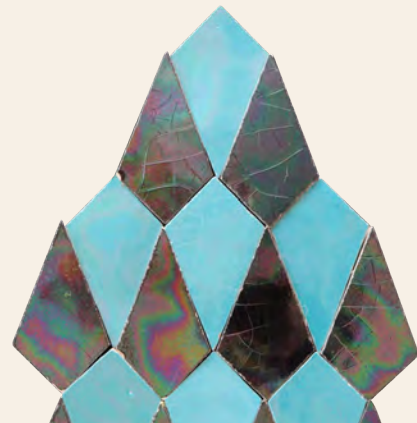
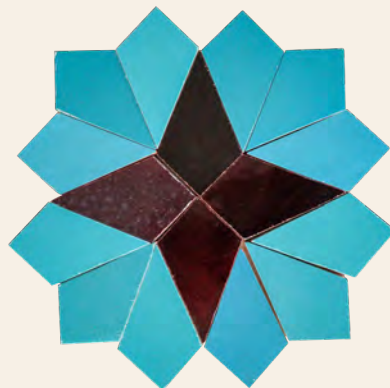

Seljuk Star

Each corner of the Seljuk Star symbolizes core values such as compassion, patience truthfulness, keeping secrets, loyalty, generosity and praising the lord of the Seljuk and Turkish culture. It has been redesigned and carefully prepared as modular facing brick and ceramic with the relief effect.

The Seljuk Tile Mosaic technique, which is made with the harmony of turquoise eggplant purple and cobalt colors both with each other and with the soil, has been another cultural heritage that we inspired.

Product Code: SY1
Piece/m² : 110 pcs
Module Weight: 107 g

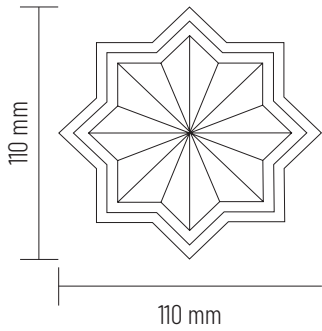

Product Code: SY2
Piece/m² : 110 pcs
Module Weight: 77 g

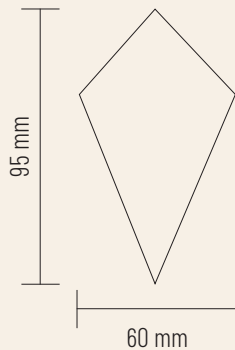
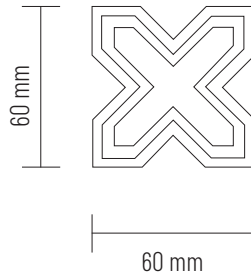

Product Code: SMO
Piece/m² : 280 pcs
Module Weight: 91,4 g



FROM MIRACLES OF NATURE
to inspiring textures...



Poseidon Series

The Poseidon Series has formed from the combination of the movement of water, the aesthetic structure of the fish scale, the inspiration from the sea and sea creatures with the character of the sea.

Calm and stormy characters of the sea has been highlighted.

**Colour and decor works can be carried out in accordance with customer request. Since our products are handmade and boutique-style manufacturing, there may be colour tone differences within and between product batches.*



SMALL

Flake

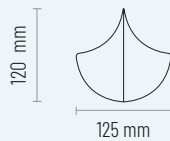

Product Code: FLK
 Piece/m²: 125 pcs
 Module Weight: 120,7 g

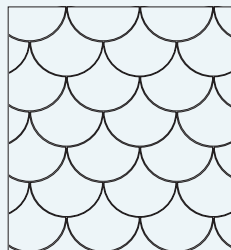

LARGE

Flake

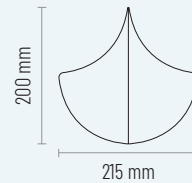

Product Code: BFLK
 Piece/m²: 50 pcs
 Module Weight: 481 g

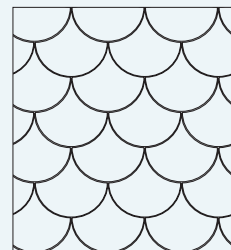

Akoya

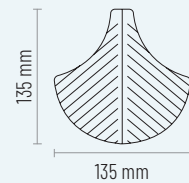

Product Code: AKO
 Piece/m²: 95 pcs
 Module Weight: 170 g

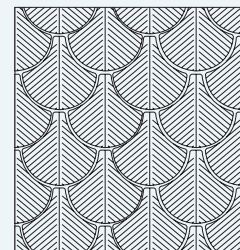

Camber

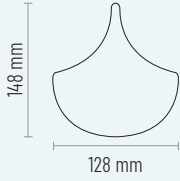

Product Code: CAM
Piece/m² : 105 pcs
Module Weight: 192,6 g

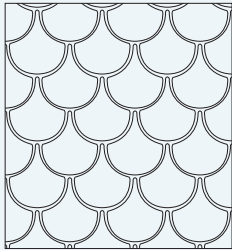

Mare

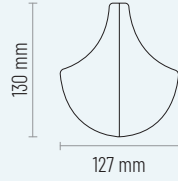

Product Code: MAR
Piece/m² : 95 pcs
Module Weight: 185 g

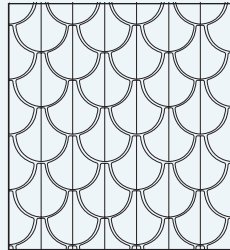

Quello

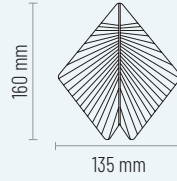

Product Code: QUE
Piece/m² : 81 pcs
Module Weight: 235 g

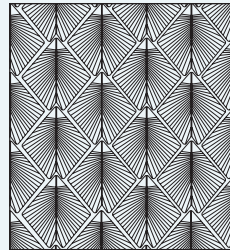

FEEL THE SERENITY OF NATURE
in your living spaces...



Flora Series

Our designs inspired by the vegetation in nature; it gives life to leaf as in Foglio. Sometimes it transforms to an endless design that comes from the harmony and holism of nature complementing each other as in Segà. Inka reminds of reminiscent of feathers flying between trees and leaves.

We also create new colours filled with the peace of green. Flora Series's designs are a metaphor that request serenity to our chaotic age.

**Colour and decor works can be carried out in accordance with customer request. Since our products are handmade and boutique-style manufacturing, there may be colour tone differences within and between product batches.*

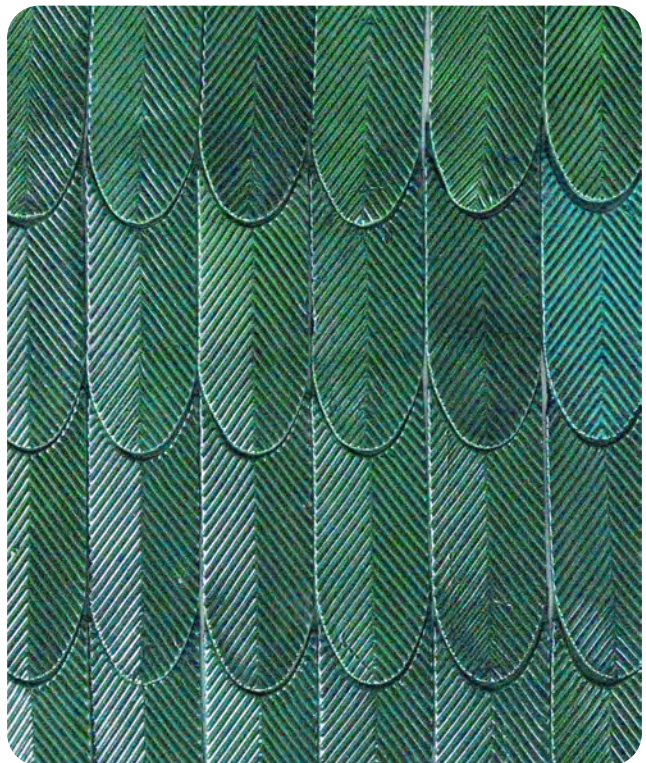

Inka

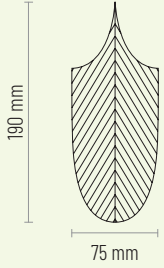

Product Code: INK
Piece/m² : 91 pcs
Module Weight: 165 g

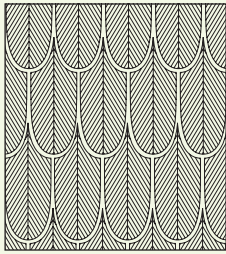

Foglia

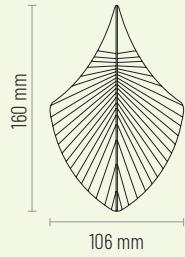

Product Code: FOG
Piece/m² : 108 pcs
Module Weight: 165 g

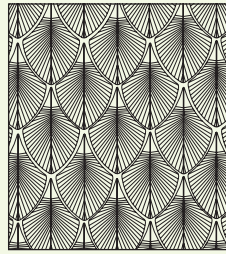

Sega

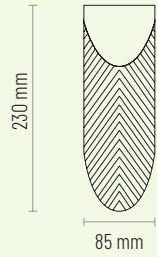
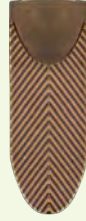

Product Code: SEG
Piece/m² : 68 pcs
Module Weight: 265 g

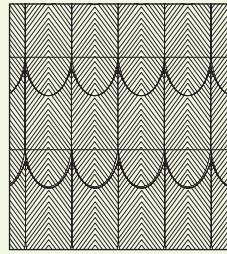

BRING THE MIRACLE OF NATURE
to your living spaces...

Miraculum Series

We inspired by the miracles of nature when we designed the Miraculum Series. The source of life is the sun and its warmth, the miracle of being and life. Some designs and colours are a combination of joy and enthusiasm of this inspiration from the energy of light. Like as Luce; an energetic and exciting, inspirational design.

We reflected the inspiration of the water that seeped drop by drop everywhere to Guta. In the miracles of nature, it would not be to be affected by gemstones. Diamond was inspired by the unique crystal structures of natural stones.

**Colour and decor works can be carried out in accordance with customer request. Since our products are handmade and boutique-style manufacturing, there may be colour tone differences within and between product batches.*



Luce

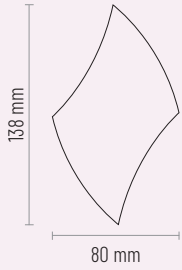

Product Code: LUC
Piece/m²: 160 pcs
Module Weight: 114 g

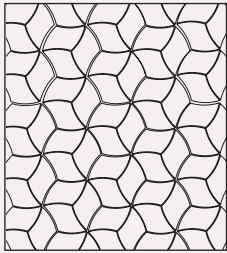

Guta

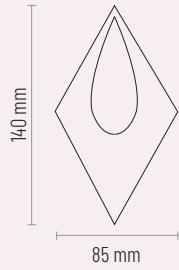

Product Code: GUT
Piece/m²: 155 pcs
Module Weight: 138 g

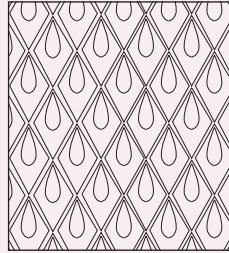

Diamond

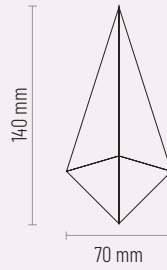

Product Code: DIA
Piece/m²: 190 pcs
Module Weight: 308 g

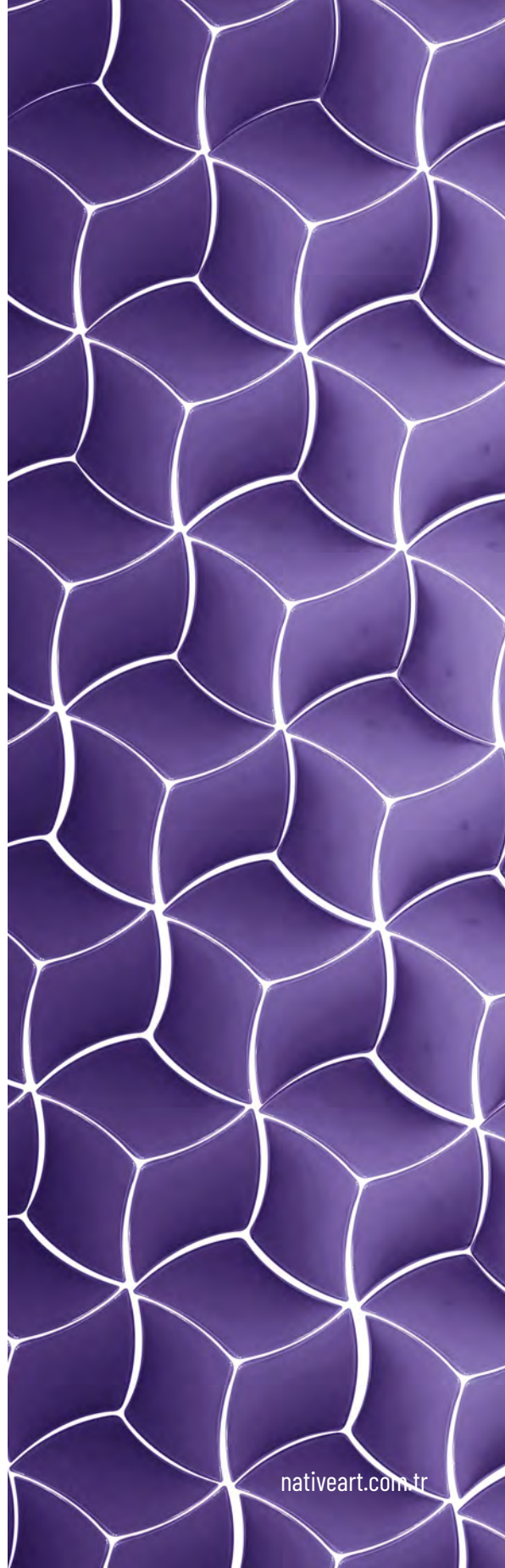
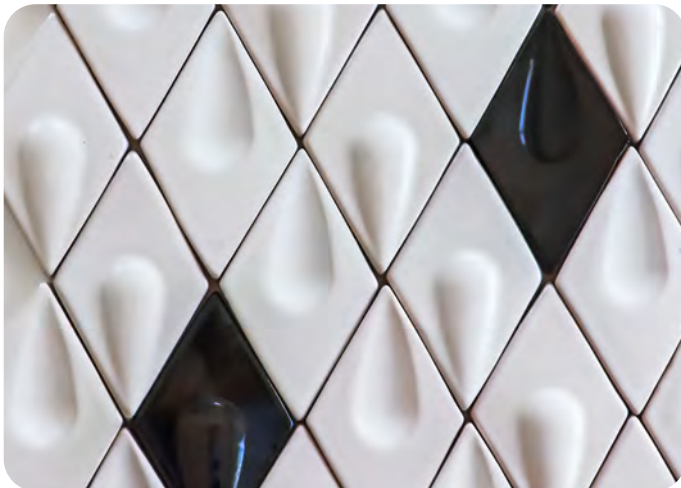
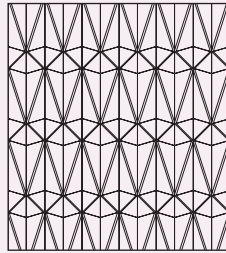

BRING THE AESTHETIC OF NATURE
to your living spaces...



Hexagon Series

Inspired by honeycomb, which forms nature's miraculous hexagon, the Hexagon Series symbolizes abundance and fertility with its three dimensional effect to your living space. The equilateral triangles that form the hexagonal structure give a feeling of beauty and balance.

Different motifs can be created with hexagons that can be combined without gaps and deep reliefs on the hexagon add movement to your spaces. The pit that settles in the hexagon creates a black hole effect (CAVUM) that swallows everything that passes near it.

**Colour and decor works can be carried out in accordance with customer request. Since our products are handmade and boutique-style manufacturing, there may be colour tone differences within and between product batches.*

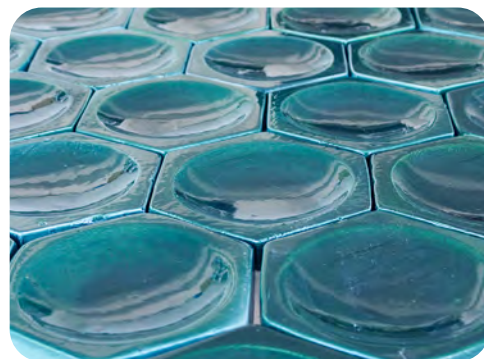

Argemonia

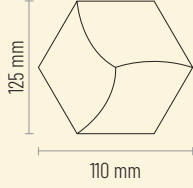

Product Code: ARG
Piece/m² : 94 pcs
Module Weight: 110 g

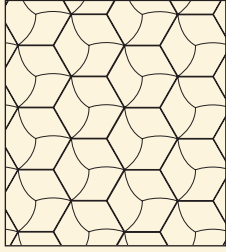

Cavum

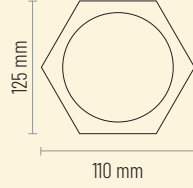
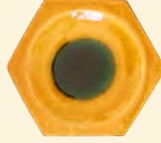

Product Code: CAV
Piece/m² : 94 pcs
Module Weight: 210 g

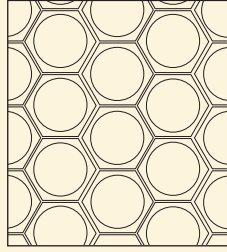

Altum

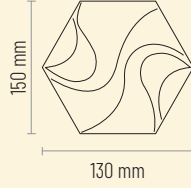

Product Code: ALT
Piece/m² : 68 pcs
Module Weight: 349 g

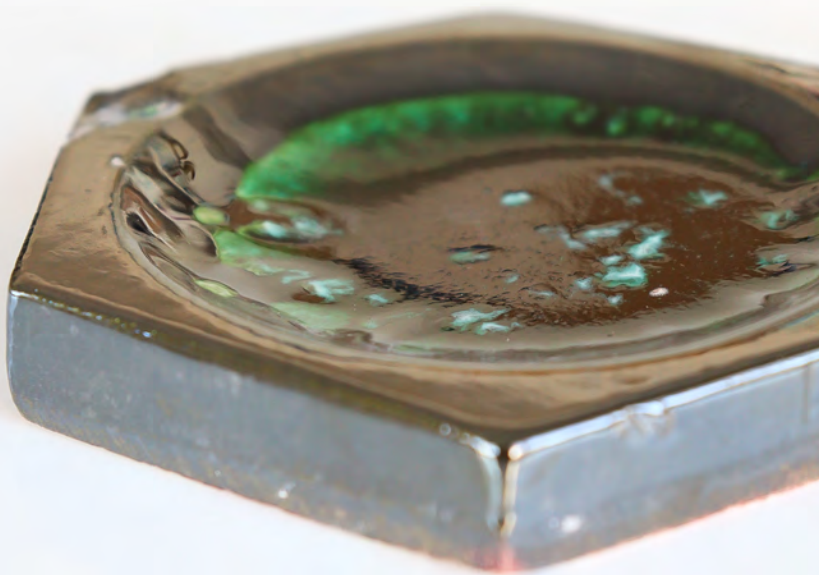
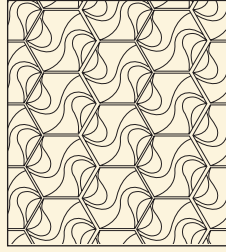

DISCOVER THE HOPE

at the end of long distances...



Via Series

Road and dream... Long ceramic designs inspired by the extended roads looks like the dreams established on the journey and integrated with the curved paths that curl inward and flowing outward.

Sometimes, in the end of journeys, dreams are realize or frustrations are happen. Even so the journey will always continue to the future without looking back.

**Colour and decor works can be carried out in accordance with customer request. Since our products are handmade and boutique-style manufacturing, there may be colour tone differences within and between product batches.*

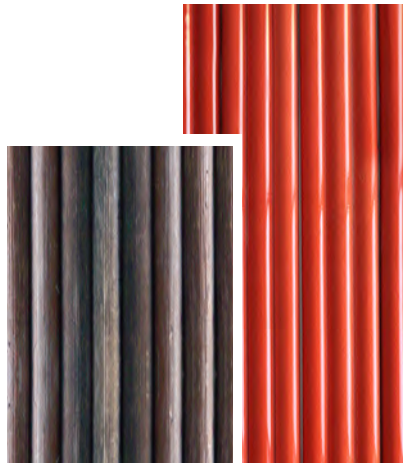

Trilho



Product Code: TRH
Piece/m² : 11 pcs
Length: 1000 mm
Module Weight: 2234 g

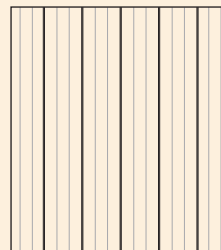

Riel

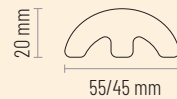

Product Code: VIA
Piece/m² : 18/22 pcs
Length: 1000 mm
Module Weight: 1358/987 g

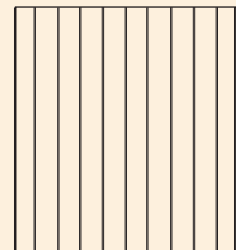

Via

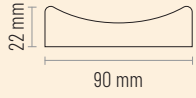

Product Code: VIA
Piece/m² : 11 pcs
Length: 1000 mm
Module Weight: 2804 g

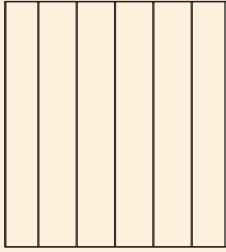

Dentes

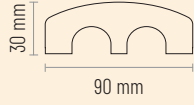

Product Code: DEN
Piece/m² : 11 pcs
Length: 1000 mm
Module Weight: 2800 g

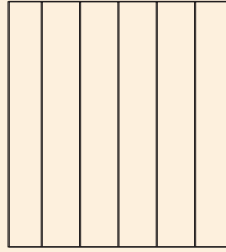

Voya



Product Code: VOY
Piece/m² : 11 pcs
Length: 1000 mm
Module Weight: 2240 g

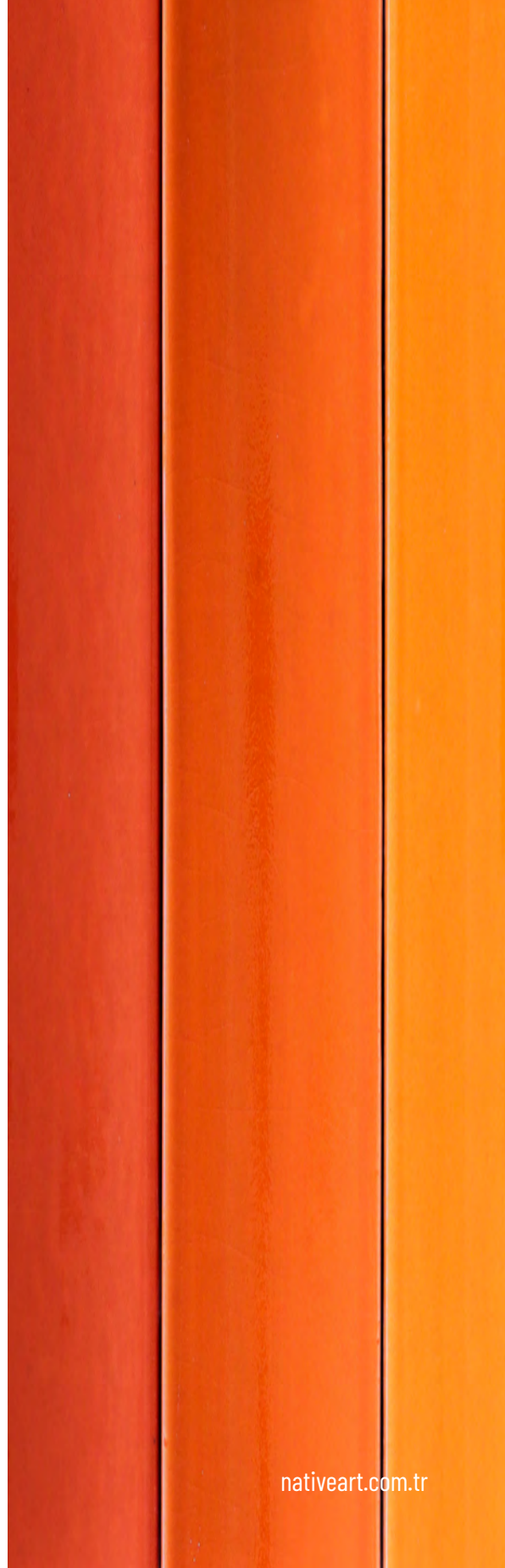
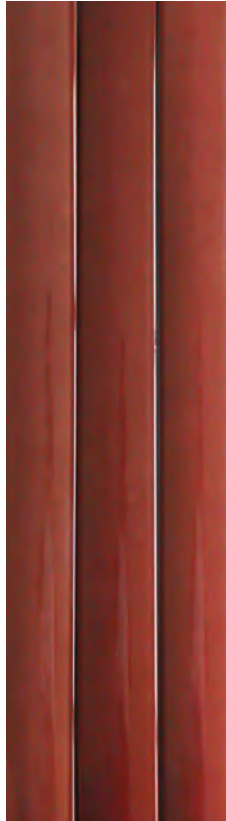
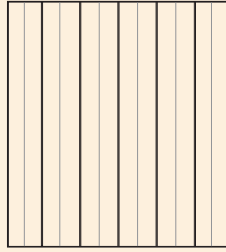



FOR AN ARTISTIC JOURNEY
through time and space...

Polygon Series

The Polygon series has been formed with the innovative interpretation of the power reflected by classical geometric shapes. The square evokes a sense of confidence with all its equal sides. The triangle is stable and balance when its base rests on it.

The pyramid, with its wide base and narrowing as you go to the top, related with hierarchy. The regular pentagon with golden ratio creates a magnificent base especially in decorations.

The rectangle evokes nobility, justice and power with its aspect ratio change. A celestial shape, the circle symbolizes modesty with its soft and curved lines.

**Colour and decor works can be carried out in accordance with customer request. Since our products are handmade and boutique-style manufacturing, there may be colour tone differences within and between product batches.*

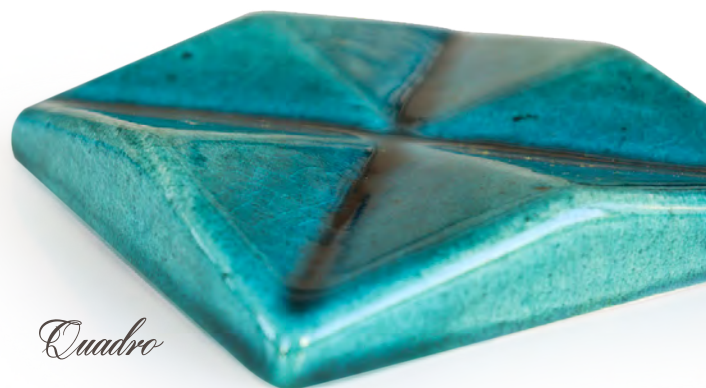

Quadro

Introvert

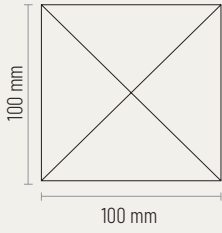

Product Code: INT
Piece/m² : 100 pcs
Module Weight: 269 g

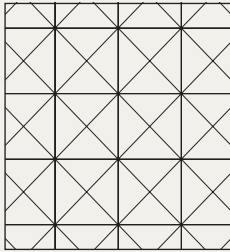

Quadro

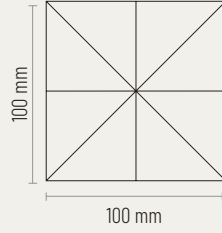

Product Code: QUA
Piece/m² : 100 pcs
Module Weight: 290 g

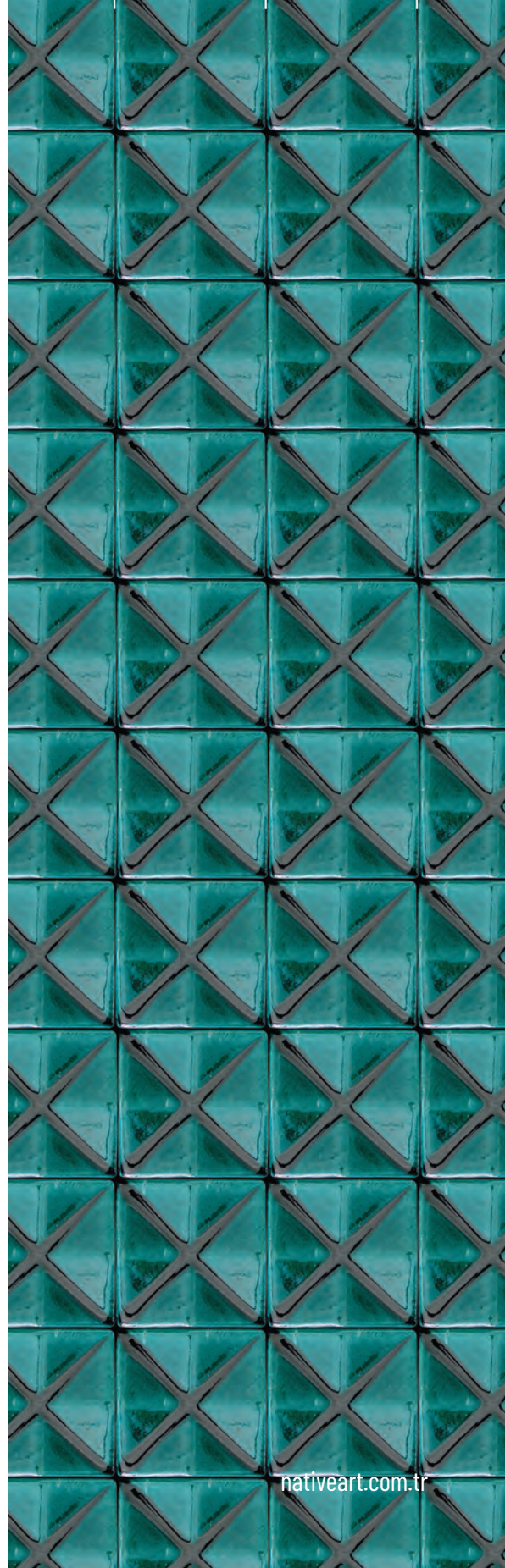
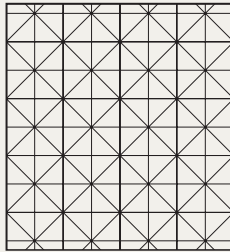



Mons

Enki

Mons

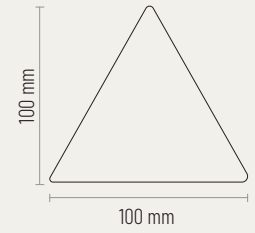
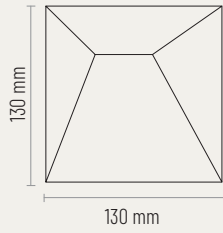
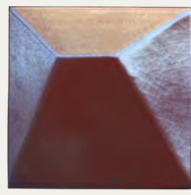

Product Code: ENK
Piece/m² : 60 pcs
Module Weight: 107 g

Product Code: MON
Piece/m² : 130 pcs
Module Weight: 135 g

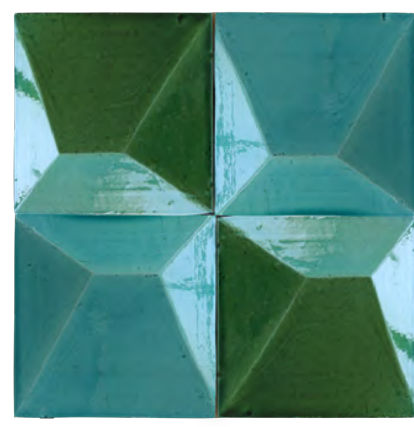
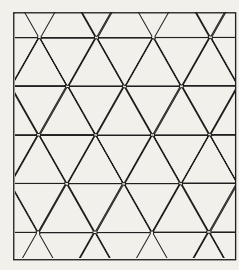
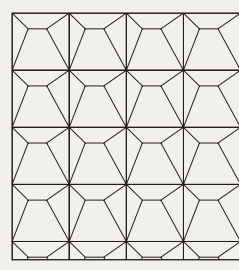

Centoventi

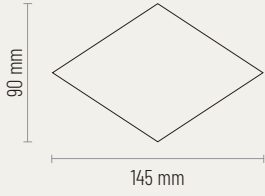
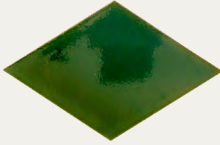

Product Code: CEN
Piece/m² : 155 pcs
Module Weight: 108 g

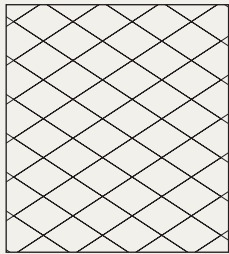

Esagoni

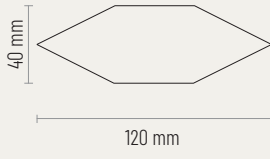

Product Code: EXA
Piece/m² : 288 pcs
Module Weight: 65 g

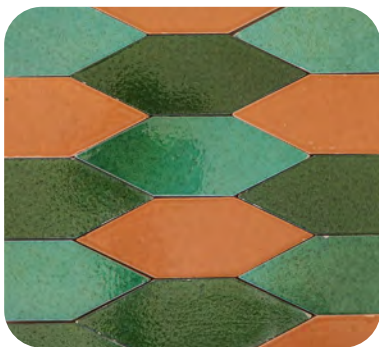
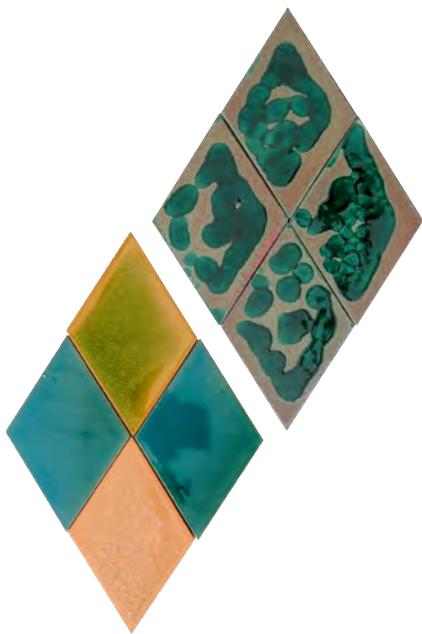
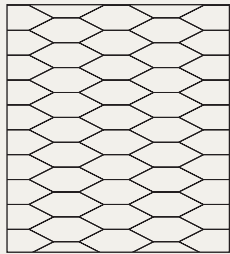

Palkas

Bipartito

Palkas

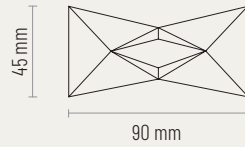
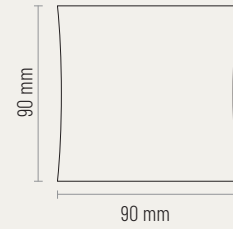
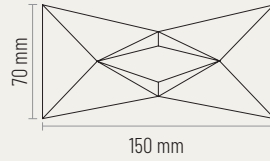

Product Code: BIP/SBIP
Piece/m² : 95/246 pcs
Module Weight: 160/115 g

Product Code: PAL
Piece/m² : 123 pcs
Module Weight: 246 g

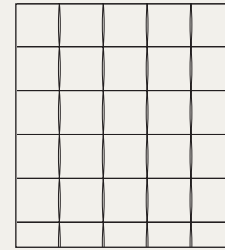
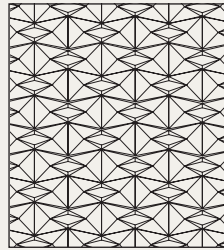

Siya

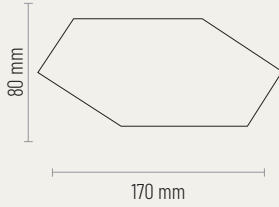

Product Code: SIY
Piece/m²: 90 pcs
Module Weight: 175,3 g

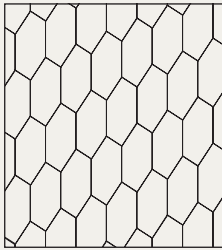

Tria

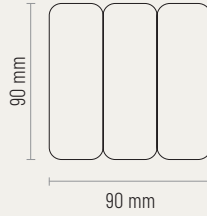

Product Code: TRI
Piece/m²: 123 pcs
Module Weight: 220 g

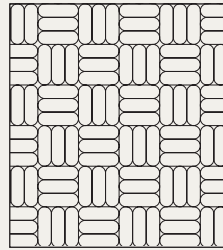



BRING THE TRACES OF FREEDOM
to your living spaces...

Rustic Series

The naturalness of the rustic style, its simplicity and elegance without details are reflected on this series. Generally, on the red terracotta clay, the freedom of the glaze is felt in the effect and color transitions.

Glaze and colors on the body are sometimes flat and calm, sometimes gathered under the influence of an attraction, and sometimes swept over the surface like dew droplets. Let the clay and the glaze dance freely.

**Colour and decor works can be carried out in accordance with customer request. Since our products are handmade and boutique-style manufacturing, there may be colour tone differences within and between product batches.*

Insignis

Product Code: INS
Module Sizes: 140x140 mm
Piece/m²: 51 pcs
Module Weight: 430 g

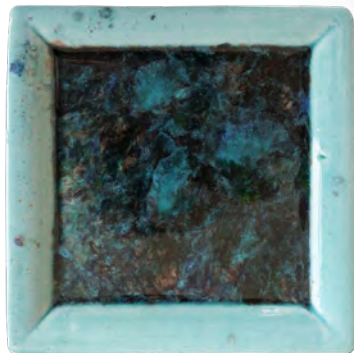

Magnes

Product Code: MAG
Module Sizes: 200x50 mm
Piece/m²: 100 pcs
Module Weight: 252 g



Ventus

Product Code: VTS
Module Sizes: 50x50 mm - 100x100 mm
Piece/m² : 400 - 100 pcs
Module Weight: 90 - 185 g



Planus

Product Code: PLS
Module Sizes: 50x50 mm - 100x100 mm
Piece/m² : 400 - 100 pcs
Module Weight: 90 - 185 g

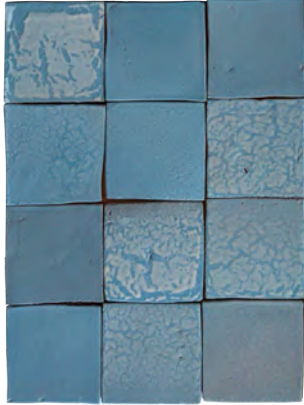

Metro Clara

Product Code: MC
Module Sizes: 100x100 mm + 150x50 mm
Piece/m² : 35 pcs + 88 pcs
Module Weight: 164,5 g + 164,5 g

Ros Rustik

Product Code: ROR
Product Sizes: 100x100 mm
Piece/m² : 100 pcs
Module Weight: 185 g



Ros Stilla

Product Code: ROR
Product Sizes: 100x100 mm
Piece/m² : 100 pcs
Module Weight: 185 g

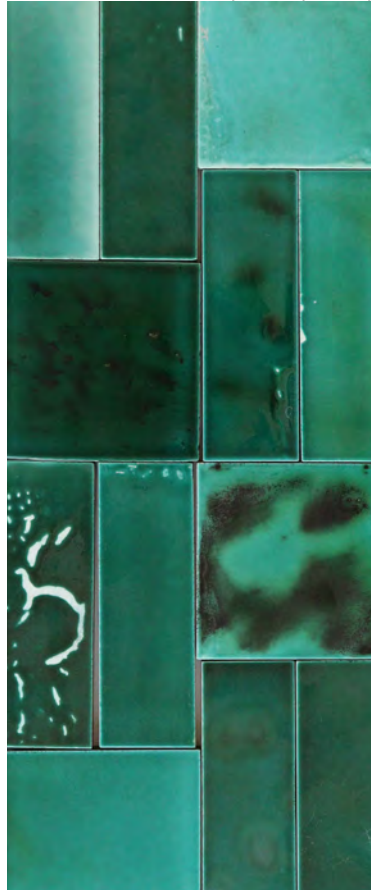

Ros Stilla
nativeart.com.tr

ALL THE COLOURS OF THE UNIVERSE
are in your living spaces...

Pixel Series

Inspired by the color pixel squares that make up the pictures of the digital world. Real life images are pixel by pixel and have billions of colors in the color gamut. Pixel panels are the minimalist approach of colours in our lives.



GLAZES

COLOUR CHART





BRIGHT GLAZES



Colour Code: 000
White



Colour Code: 300
Soft Yellow



Colour Code: 400
Light Mint Green



Colour Code: 500
Light Petroleum Blue



Colour Code: 001
Off White



Colour Code: 301
Yellow



Colour Code: 401
Mint Green



Colour Code: 501
Petroleum Blue



Colour Code: 200
Light Mink



Colour Code: 302
Dark Yellow



Colour Code: 402
Dark Mint Green



Colour Code: 502
Dark Petroleum Blue



Colour Code: 201
Gray Mink



Colour Code: 303
Mustard Yellow



Colour Code: 405
Light Green



Colour Code: 503
Baby Blue



Colour Code: 202
Mink



Colour Code: 304
Light Caramel



Colour Code: 406
Green



Colour Code: 504
Blue



Colour Code: 203
Dark Mink



Colour Code: 305
Caramel



Colour Code: 410
Khaki



Colour Code: 505
Coral Blue



Colour Code: 506
Azure Blue



Colour Code: 507
Night Blue



Colour Code: 508
Light Cobalt

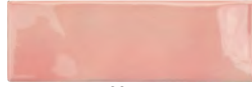

Colour Code: 700
Powder Pink

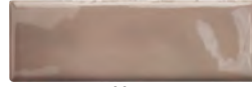

Colour Code: 900
Light Brown



Colour Code: 990
Light Gray



Colour Code: 509
Cobalt



Colour Code: 701
Newyork Pink

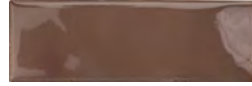

Colour Code: 901
Brown



Colour Code: 991
Gray



Colour Code: 510
Dark Cobalt



Colour Code: 702
Salmon Pink



Colour Code: 902
Dark Brown



Colour Code: 995
Smoked



Colour Code: 600
Amethyst Purple



Colour Code: 800
Crimson Red



Colour Code: 903
Mahogany



Colour Code: 996
Anthracite



Colour Code: 601
Light Purple



Colour Code: 801
Scarlet Red



Colour Code: 999
Black



Colour Code: 602
Lilac



Colour Code: 802
Vine Red



Colour Code: 805
Burgundy

MATTE GLAZES



Colour Code: 155
Matte White



Colour Code: 355
Matte Light Green



Colour Code: 455
Matte Baby Blue



Colour Code: 655
Matte Light Purple



Colour Code: 156
Matte Off White



Colour Code: 356
Matte Green



Colour Code: 456
Matte Blue



Colour Code: 656
Matte Purple



Colour Code: 255
Matte Soft Yellow



Colour Code: 357
Matte Dark Green



Colour Code: 457
Matte Dark Blue



Colour Code: 657
Matte Dark Purple



Colour Code: 256
Matte Light Yellow



Colour Code: 385
Matte Light Petroleum Blue



Colour Code: 257
Matte Yellow



Colour Code: 386
Matte Petroleum Blue



Colour Code: 387
Matte Dark Petroleum Blue



Colour Code: 755
Matte Light Salmon



Colour Code: 855
Matte Ecru

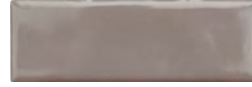

Colour Code: 860
Matte Beige



Colour Code: 756
Matte Salmon



Colour Code: 856
Matte Mustard Yellow



Colour Code: 955
Matte Light Gray



Colour Code: 757
Matte Dark Salmon



Colour Code: 857
Matte Light Brown



Colour Code: 956
Matte Smoked



Colour Code: 765
Matte Powder Pink



Colour Code: 858
Matte Brown

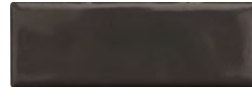

Colour Code: 957
Matte Anthracite



Colour Code: 766
Matte New York Pink



Colour Code: 859
Matte Dark Brown



Colour Code: 998
Matte Black



Colour Code: 767
Matte Dark New York Pink

CRACKLE GLAZES



Colour Code: 1000
White-CR

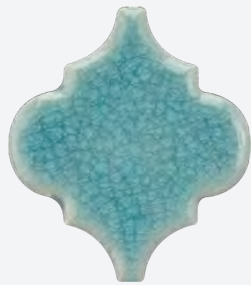

Colour Code: 1001
Ice Blue-CR

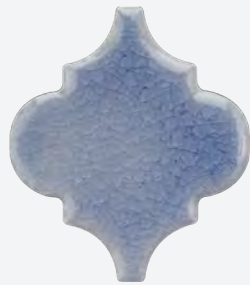

Colour Code: 1002
Light Cobalt-CR

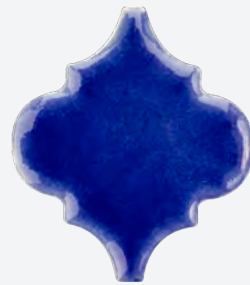

Colour Code: 1003
Cobalt-CR

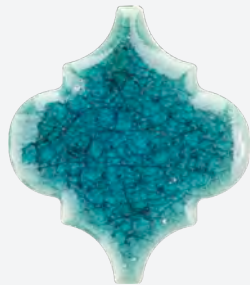

Colour Code: 1004
Turquoise-CR

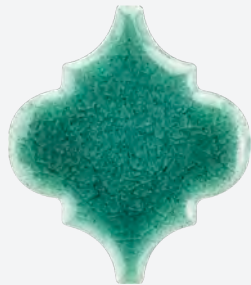

Colour Code: 1005
Green-CR



Colour Code: 1006
Emerald-CR

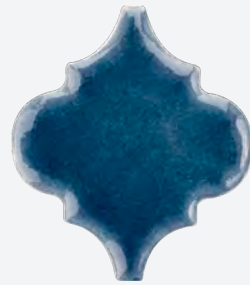

Colour Code: 1007
French Blue-CR

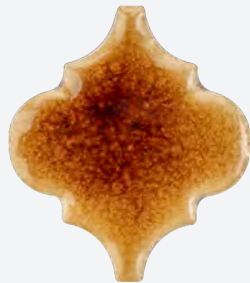

Colour Code: 1008
Honey Yellow-CR



Colour Code: 1009
Beige-CR



Colour Code: 1010
Gray-CR



Colour Code: 1011
Burgundy-CR



Colour Code: 1012
Manganese Purple-CR



Colour Code: 1013
Black-CR

METALLIC GLAZES



Colour Code: 2000
Bright Metallic
Raku Effect



Colour Code: 2001
Matt Metallic
Copper Pearlescent Brown



Colour Code: 2002
Matt Metallic
Copper Leather Effect



Colour Code: 2003
Matte Metallic
Dark Anthracite



Colour Code: 2004
Matt Metallic
Copper Leather Effect



Colour Code: 2005
Matt Metallic
Gold Effect



Colour Code: 2007
Matt Metallic
Gold Pearlescent Brown

ANTIQUÉ GLAZES



Colour Code: A001
Green-CRA

Colour Code: A002
Brown-CRA



Colour Code: A003
Brown Orange Effect-CRA

Colour Code: A004
Metallic Blue Black-CRA





nativeart.com.tr

75. Yıl OSB Mah. 108. Cad No:1 Odunpazarı, Eskişehir / Türkiye
Telefon & Faks: +90 (222) 229 09 90
e-mail: info@nativeart.com.tr